

# DINGMAN TOWNSHIP FIRE DEPT. MILFORD, PA

S.O. 144472 / QUOTE 104414  
AERIAL BODY W/ SIDE STACKER HOSEBED  
E-ONE CYCLONE CHASSIS  
HR100 LADDER

THIS DRAWING IS FOR REFERENCE PURPOSES. ALL DIMENSIONS ARE SUBJECT TO MINOR VARIATIONS DUE TO MANUFACTURING PROCESSES.

(FOR INTERNAL SALES PURPOSES ONLY)

DEALER APPROVAL \_\_\_\_\_ DATE \_\_\_\_\_

DATE \_\_\_\_\_

AS IS

CUSTOMER APPROVAL \_\_\_\_\_ DATE \_\_\_\_\_

DATE \_\_\_\_\_

WITH REVISIONS

COMPT.		OPENING		INTERIOR DIMENSION			
L1	44W	63H	44W	35H	9D	UPPER	
R1	29W	63H	29W	35H	9D	UPPER	
L2	42W	60H	44W	12H	21D	UPPER	
R2	44W	30H	44W	30H	26D	LOWER	
L3	69W	23H	69W	23H	NOTED		
R3	45W	24H	45W	24H	NOTED		
L4	43W	42H	45W	23H	23D	UPPER	
			45W	28H	NOTED	LOWER	

GROUND LADDERS			
ITEM	LADDER LENGTH	MODEL NUMBER	QTY
A	35' 2-SECT.	1200-A 35'	2
B	24' 2-SECT.	900-A 24'	1
C	16' ROOF	875-A 16'	1
D	14' ROOF	775-A 14'	1
E	14' FRESNO	701-A 14'	1
F	10' FOLDING	585-A 10'	1
G	LITTLE GIANT	MODEL 17	1

HOSE LOAD:	
300'	OF 2.50" DJ
200'	OF 1.75" DJ
200'	OF 1.75" DJ
500'	OF 5.00" LDH

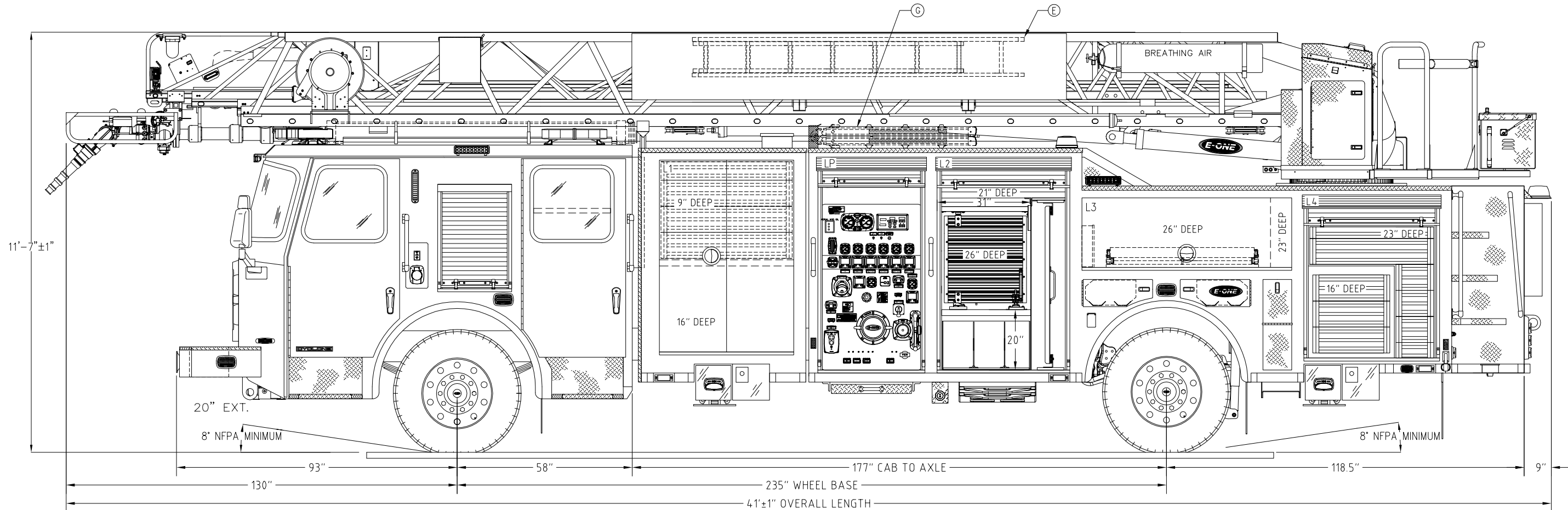
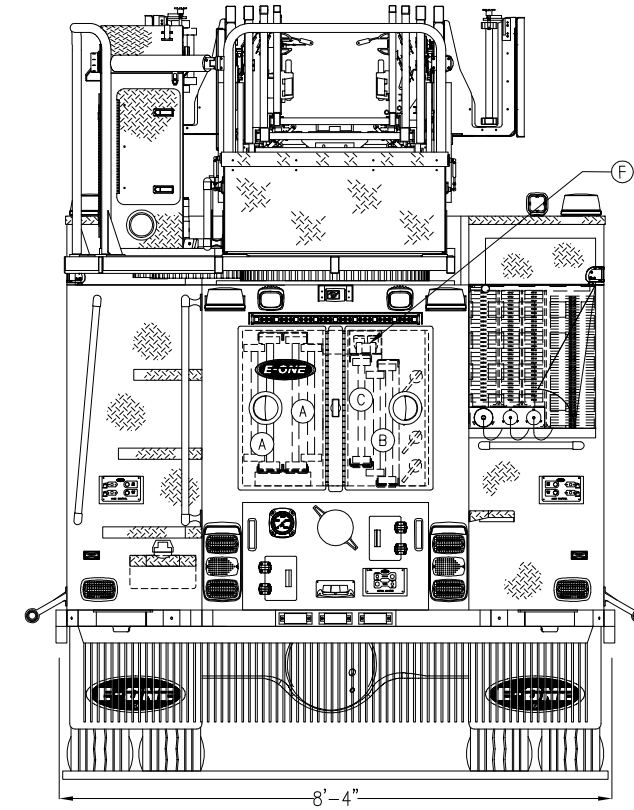

DATE	REV	DESCRIPTION	DATE	APPROVED
2021-MAR-05				

Date Printed: 2021-03-11 at 13:23:02 EST Username: dtallman  
 Creator: Cret, Gabe Jr. Version: A.7 State: Released  
 Context: Aerial Location: /Default/144472/Sales Drawings

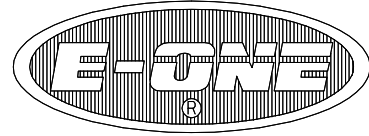

# DINGMAN TOWNSHIP FIRE DEPT. MILFORD, PA

S.O. 144472 / QUOTE 104414  
 AERIAL BODY W/ SIDE STACKER HOSEBED  
 E-ONE CYCLONE CHASSIS  
 HR100 LADDER

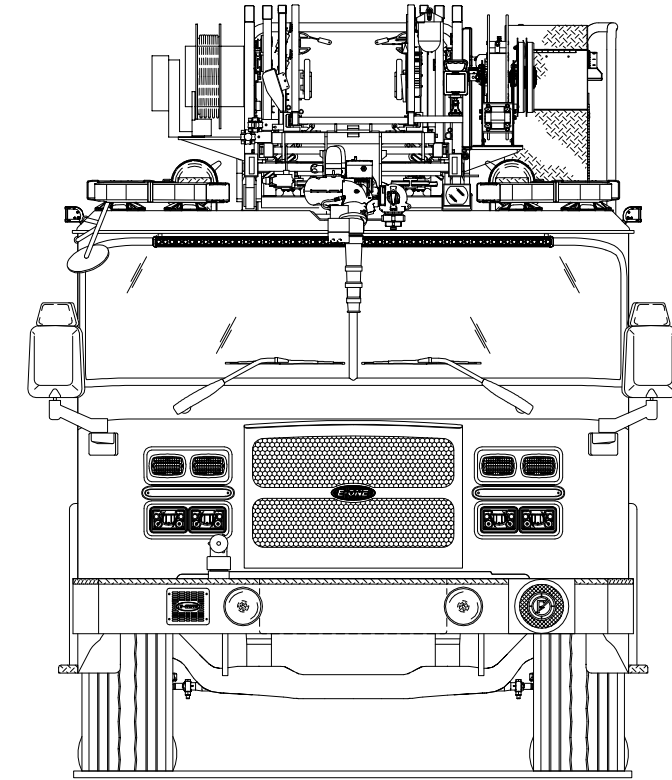

THIS DRAWING IS FOR REFERENCE PURPOSES. ALL DIMENSIONS ARE SUBJECT TO MINOR VARIATIONS DUE TO MANUFACTURING PROCESSES.

(FOR INTERNAL SALES PURPOSES ONLY)

DEALER APPROVAL _____	DATE _____	<input type="checkbox"/> AS IS
CUSTOMER APPROVAL _____	DATE _____	<input type="checkbox"/> WITH REVISIONS

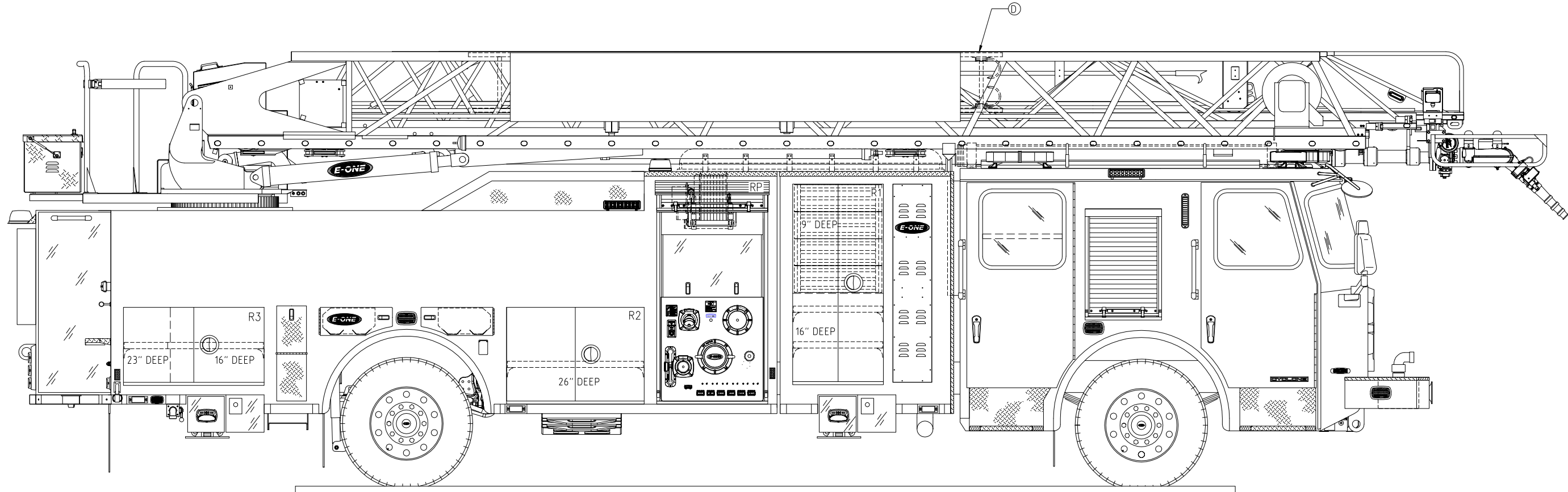

Date Printed: 2021-03-11 at 13:23:02 EST Username: dtallman  
 Creator: Cret, Gabe Jr. Version: A.7 State: Released  
 Context: Aerial Location: /Default/144000/144472/Sales Drawings

DATE	BY	DESCRIPTION	DATE	BY	DESCRIPTION
2021-MAR-05	GACRE	REV			
		APPROVAL			

SHEET 2 OF 2